

LinkPower™ LPS SM BIDI 2612T/2612Ti LC & 2613R/2613Ri LC

RoHS Compliant 1.25G 1310/1550nm & 1550/1310nm 20km Transceivers

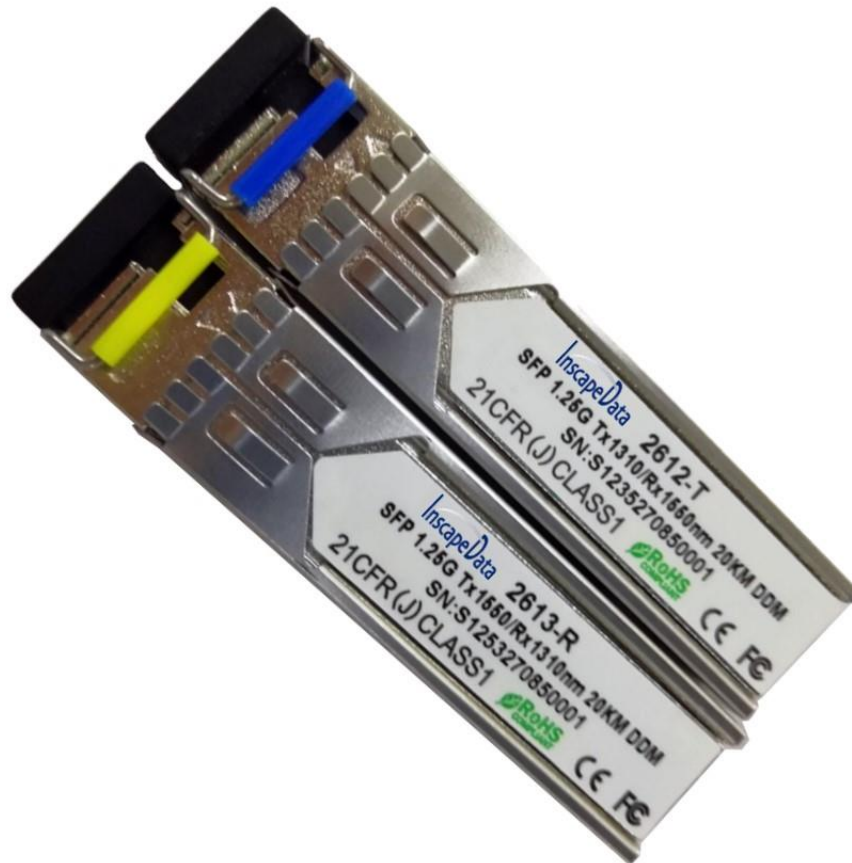

Product Features

1. Supports 1.25Gbps/1.0625Gbps bit rates
2. Bi-Directional, BIDI, SC SM connector
3. Hot pluggable SFP footprint
 - 2612T / 2612Ti: 1310nm FP laser and 1550nm PIN photo detector
 - 2613R / 2613Ri: 1550nm DFB laser and 1310nm PIN photo detector
4. Applicable for 20Km SMF connection
5. Low power consumption, < 0.8W
6. Digital Diagnostic Monitor Interface
7. Compliant with SFP MSA and SFF-8472
8. Very low EMI and excellent ESD protection
9. Operating temperature:

Commercial grade: LPS SC SM 2612T & 2613R, 0 to 70 °C

Industrial grade: LPS SC SM 2612Ti & 2613Ri, -40 to 85°C

Applications

1. Gigabit Ethernet
2. Fiber Channel
3. Switch to Switch interface
4. Switched backplane applications
5. Router/Server interface
6. Other Optical Links

Product Descriptions

Inscap Data's LinkPower™ LPS SC SM 2612T & 2613R, Single Mode, SFP-BIDI, Bidirectional, transceivers are high performance, cost effective modules supporting dual data-rate of 1.25Gbps/1.0625Gbps and 20km transmission distance with SMF. The transceiver consists of three sections: a FP/DFB laser transmitter, a PIN photodiode integrated with a trans-impedance preamplifier (TIA) and MCU control unit. All modules satisfy class I laser safety requirements. The transceivers are compatible with SFP Multi-Source Agreement (MSA) and SFF-8472. For further information, please refer to SFP MSA.

Functional Diagram

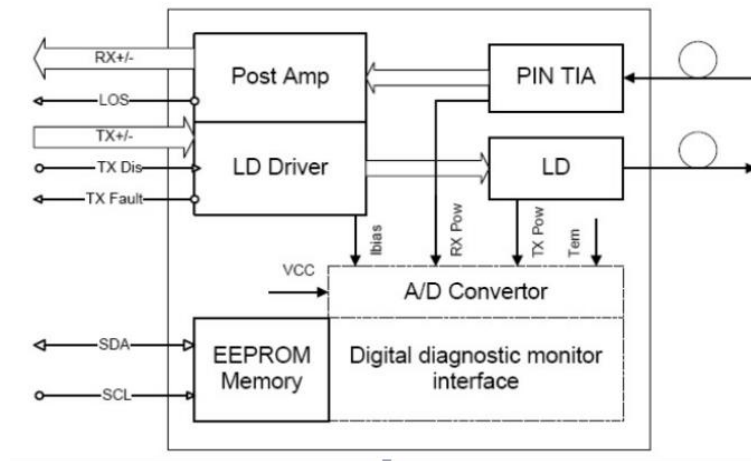

Inscap Data Corporation
1620 Oakland Road, Suite D101, San Jose, CA 95131, U.S.A.
PHONE: +1.408.392.9800 FAX: +1.408.392.9812
Corporate Website: www.inscapdata.com
EMAIL: sales@inscapdata.com

© Copyright 2018, Inscap Data Corporation, All Rights Reserved. LinkPower and Inscap Data are trademarks of Inscap Data Corporation, REV. 1.1
Disclaimer: While every effort is made to ensure the information given is accurate, Inscap Data Corporation does not accept liability for any errors or mistakes which may arise.
All specifications are subject to change without notice.

Absolute Maximum Ratings

Parameter	Symbol	Min.	Max.	Unit	Note
Supply Voltage	V _{cc}	-0.5	4.0	V	
Storage Temperature	T _s	-40	85	°C	
Relative Humidity	RH	0	85	%	

Note: Stress in excess of the maximum absolute ratings can cause permanent damage to the transceiver.

General Operating Characteristics

Parameter	Symbol	Min.	Type	Max.	Unit	Note
Data Rate	DR	1.0625	1.25		Gb/s	
Supply Voltage	V _{cc}	3.13	3.3	3.47	V	
Supply Current	I _{ccs}			220	mA	
Operating Case Temp.	T _c	0		70	°C	
	T _I	-40		85		

Electrical Characteristics (T_{OP(C)} = 0 to 70 °C, V_{CC} = 3.13 to 3.47 V)

Parameter	Symbol	Min.	Type	Max.	Unit	Note
Transmitter						
Differential data input swing	V _{IN,PP}	120		820	mV _{pp}	1
Tx Disable Input-High	V _{IH}	2.0		V _{cc} +0.3	V	
Tx Disable Input-Low	V _{IL}	0		0.8	V	
Tx Fault Output-High	V _{OH}	2.0		V _{cc} +0.3	V	2
Tx Fault Output-Low	V _{OL}	0		0.8	V	2
Input differential impedance	R _{in}		100		Ω	
Receiver						
Differential data output swing	V _{out,pp}	340	650	800	mV _{pp}	3
Rx LOS Output-High	V _{ROH}	2.0		V _{cc} +0.3	V	2
Rx LOS Output-Low	V _{ROL}	0		0.8	V	2

Notes:

1. TD+/- are internally AC coupled with 100Ω differential termination inside the module.
2. Tx Fault and Rx LOS are open collector outputs, which should be pulled up with 4.7k to 10kΩ resistors on the host board. Pull up voltage between 2.0V and V_{cc}+0.3V.
3. RD+/- outputs are internally AC coupled, and should be terminated with 100Ω (differential) at the user SERDES.

Inscap Data Corporation
 1620 Oakland Road, Suite D101, San Jose, CA 95131, U.S.A.
PHONE: +1.408.392.9800 **FAX:** +1.408.392.9812
Corporate Website: www.inscapedata.com
EMAIL: sales@inscapedata.com

© Copyright 2018, Inscap Data Corporation, All Rights Reserved. LinkPower and Inscap Data are trademarks of Inscap Data Corporation, REV. 1.1
 Disclaimer: While every effort is made to ensure the information given is accurate, Inscap Data Corporation does not accept liability for any errors or mistakes which may arise.
 All specifications are subject to change without notice.

Optical Characteristics (T_{OP(C)} = 0 to 70 °C, V_{CC} = 3.13 to 3.47 V)

Parameter	Symbol	Min.	Type	Max.	Unit	Note
Transmitter						
Operating Wavelength	λ	1270	1310	1360	nm	2612-T
		1510	1550	1570		2613-R
Ave. output power (Enabled)	P _{AVE}	-9		-3	dBm	1
Extinction Ratio	ER	9			dB	1
Side-Mode Suppression Ratio	SMSR	30			dB	
RMS spectral width 1310nm FP	$\Delta\lambda$			3	nm	
RMS spectral width 1550nm DFB				1	nm	
Rise/Fall time (20%~80%)	T _r /T _f			0.26	ns	2
Dispersion penalty	T _{DP}			3.9	dB	
Output Optical Eye	Compliant with IEEE802.3 z (class 1 aser safety)					
Receiver						
Operating Wavelength	λ	1510	1550	1570	nm	2612-T
		1270	1310	1360		2613-R
Receiver Sensitivity	P _{SEN1}			-22	dBm	3
Overload	P _{AVE}	-3			dBm	3
LOS Assert	P _a	-35			dBm	
LOS De-assert	P _d			-24	dBm	
LOS Hysteresis	P _d -P _a	0.5			dB	

Notes:

1. Measured at 1250Mb/s with PRBS 2²³-1 NRZ test pattern.
2. Unfiltered, measured with a PRBS 2²³-1 test pattern @1.25Gbps
3. Measured at 1250Mb/s with PRBS 2²³-1 NRZ test pattern for BER < 1x10⁻¹²

Pin Definition And Functions

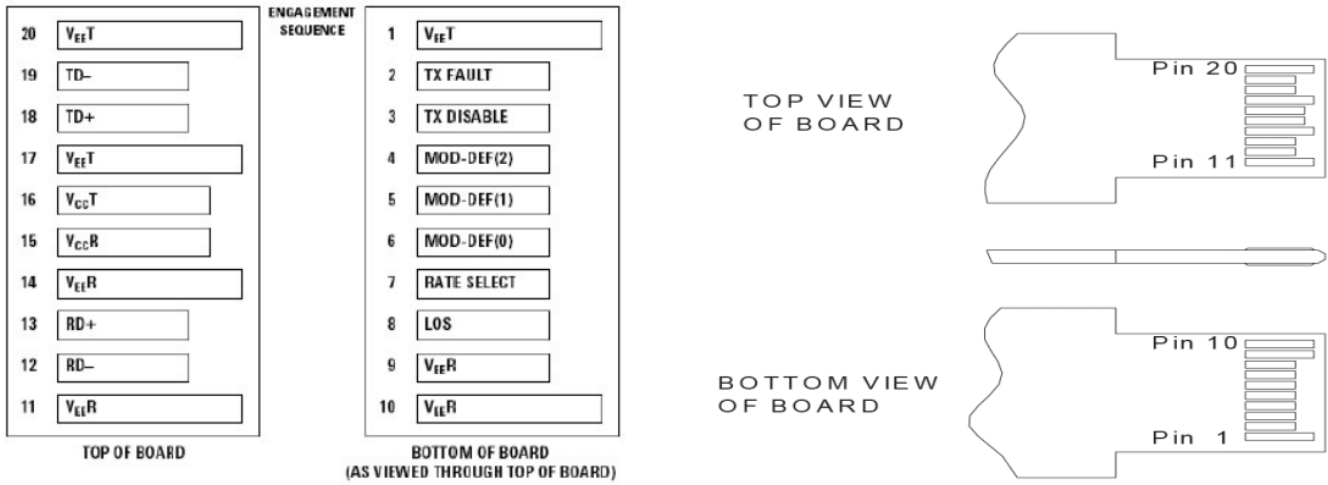

Pin	Symbol	Name/Description	Notes
1	V _{ee} T	Tx ground	
2	Tx Fault	Tx fault indication, Open Collector Output, active “H”	1
3	Tx Disable	LVTTL Input, internal pull-up, Tx disabled on “H”	2
4	MOD-DEF2	2 wire serial interface data input/output (SDA)	3
5	MOD-DEF1	2 wire serial interface clock input (SCL)	3
6	MOD-DEF0	Model present indication	3
7	Rate select	No connection	
8	LOS	Rx loss of signal, Open Collector Output, active “H”	4
9	V _{ee} R	Rx ground	
10	V _{ee} R	Rx ground	
11	V _{ee} R	Rx ground	
12	RD-	Inverse received data out	5
13	RD+	Received data out	5
14	V _{ee} R	Rx ground	
15	V _{cc} R	Rx power supply	
16	V _{cc} T	Tx power supply	
17	V _{ee} T	Tx ground	
18	TD+	Transmit data in	6
19	TD-	Inverse transmit data in	6
20	V _{ee} T	Tx ground	

Notes:

- When high, this output indicates a laser fault of some kind. Low indicates normal operation. And should be pulled up with a 4.7 – 10K Ω resistor on the host board.
- TX disable is an input that is used to shut down the transmitter optical output. It is pulled up within the module with a 4.7 – 10K Ω resistor. Its states are:

Low (0 – 0.8V): Transmitter on ($>0.8, <2.0V$): Undefined

Inscape Data Corporation
 1620 Oakland Road, Suite D101, San Jose, CA 95131, U.S.A.
 PHONE: +1.408.392.9800 FAX: +1.408.392.9812
 Corporate Website: www.inscapedata.com
 EMAIL: sales@inscapedata.com

High (2.0V~Vcc+0.3V): Transmitter Disabled Open: Transmitter Disabled

3.Mod-Def 0,1,2. These are the module definition pins. They should be pulled up with a 4.7K – 10KΩ resistor on the host board. The pull-up voltage shall be between 2.0V~Vcc+0.3V.

Mod-Def 0 has been grounded by the module to indicate that the module is present

Mod-Def 1 is the clock line of two wire serial interface for serial ID

Mod-Def 2 is the data line of two wire serial interface for serial ID

4.When high, this output indicates loss of signal (LOS). Low indicates normal operation.

5.RD+/-: These are the differential receiver outputs. They are AC coupled 100Ω differential lines which should be terminated with 100Ω (differential) at the user SERDES. The AC coupling is done inside the module and is thus not required on the host board.

6. TD+/-: These are the differential transmitter inputs. They are AC-coupled, differential lines with 100Ω differential termination inside the module. The AC coupling is done inside the module and is thus not required on the host board.

Digital Diagnostic Specifications

The transceivers can be used in host systems that require either internally or externally calibrated digital diagnostics.

Parameter	Symbol	Units	Min.	Max.	Accuracy	Note
Transceiver temperature	DTemp-E	°C	-5	+75	±5°C	
Transceiver supply voltage	DVoltage	V	2.8	4.0	±3%	
Transmitter bias current	DBias	mA	2	80	±10%	1
Transmitter output power	DTx-Power	dBm	-12	0	±3dB	
Receiver average input power	DRx-Power	dBm	-25	0	±3dB	

Notes:

1. The accuracy of the Tx bias current is 10% of the actual current from the laser driver to the laser
3. Internal/ External Calibration compatible.

Typical Interface Circuit

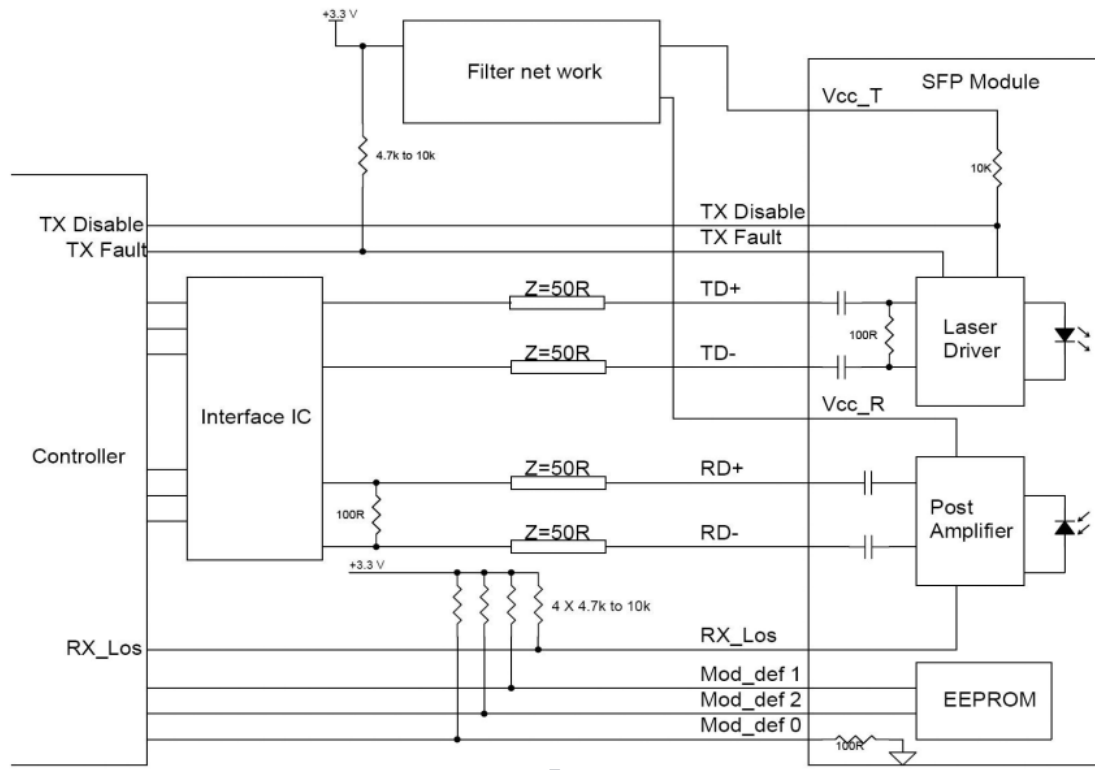

Package Dimensions

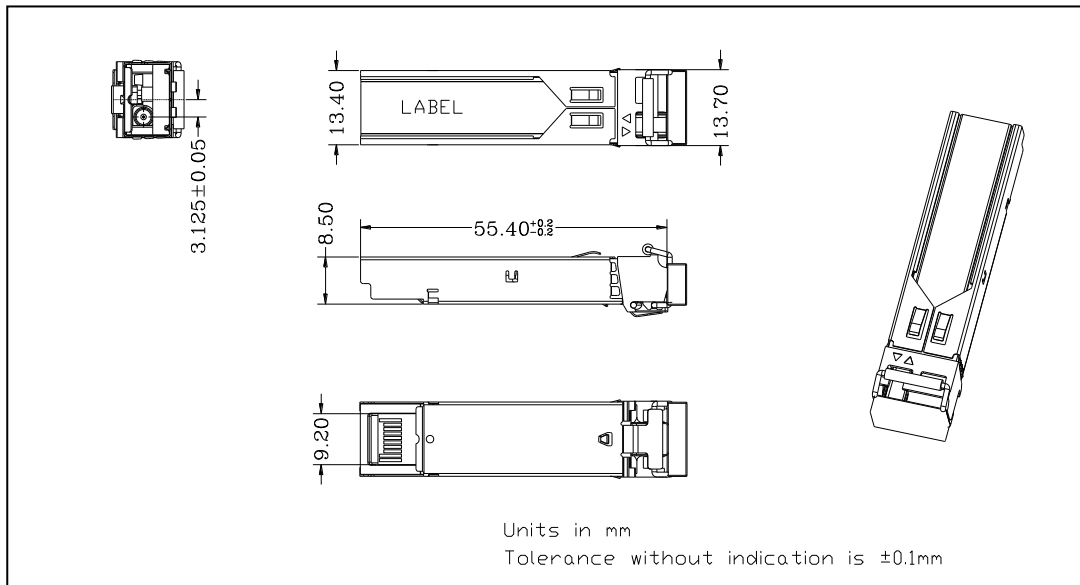

Wavelength	Latch Color
TX 1310nm	Blue
TX 1550nm	Yellow

Inscap Data Corporation
 1620 Oakland Road, Suite D101, San Jose, CA 95131, U.S.A.
PHONE: +1.408.392.9800 **FAX:** +1.408.392.9812
Corporate Website: www.inscapedata.com
EMAIL: sales@inscapedata.com

© Copyright 2018, Inscap Data Corporation, All Rights Reserved. LinkPower and Inscap Data are trademarks of Inscap Data Corporation, REV. 1.1
 Disclaimer: While every effort is made to ensure the information given is accurate, Inscap Data Corporation does not accept liability for any errors or mistakes which may arise.
 All specifications are subject to change without notice.

Ordering Information

Part Number	Description
1. LPS SM BIDI 2612T LC	Single Mode SFP BIDI, Single Fiber, LC, 1.25G ,1310/1550nm ,20Km, 0 ~ 70°C, with DDM, Commercial Grade
2. LPS SM BIDI 2613R LC	Single Mode FP BIDI, Single Fiber, LC, 1.25G ,1550/1310nm ,20Km, 0 ~ 70°C, with DDM, Commercial Grade
3. LPS SM BIDI 2612Ti LC	Single Mode SFP BIDI, Single Fiber, LC, 1.25G ,1310/1550nm ,20Km, -40 ~ 85°C, with DDM, Industrial Grade
4. LPS SM BIDI 2613Ri LC	Single Mode SFP BIDI, Single Fiber, LC, 1.25G ,1550/1310nm ,20Km, -40 ~ 85°C, with DDM, Industrial Grade

Inscape Data Corporation
1620 Oakland Road, Suite D101, San Jose, CA 95131, U.S.A.
PHONE: +1.408.392.9800 **FAX:** +1.408.392.9812
Corporate Website: www.inscapedata.com
EMAIL: sales@inscapedata.com

© Copyright 2018, Inscape Data Corporation, All Rights Reserved. LinkPower and Inscape Data are trademarks of Inscape Data Corporation, REV. 1.1
Disclaimer: While every effort is made to ensure the information given is accurate, Inscape Data Corporation does not accept liability for any errors or mistakes which may arise.
All specifications are subject to change without notice.