

## LinkPower™ LPS LC SM 2632 / 2632i

RoHS Compliant 1.25Gbps 1310nm Optical 20km Transceiver



## Product Features

1. Supports 1.25Gbps/1.0625Gbps bit rates
2. Duplex Single Mode LC connector
3. Hot pluggable SFP footprint
4. 1310nm FP laser transmitter and PIN photo-detector
5. Applicable for 20Km SMF connection
6. Low power consumption, < 0.8W
7. Digital Diagnostic Monitor Interface
8. Compliant with SFP MSA and SFF-8472
9. Very low EMI and excellent ESD protection
10. Operating case temperature:  
Commercial grade: LPS LC SM 2632, 0 to 70 °C  
Industrial grade: LPS LC SM 2632i, -40 to 85°C

## Applications

1. Gigabit Ethernet
2. Fiber Channel
3. Switch to Switch interface
4. Switched backplane applications
5. Router/Server interface
6. Other optical transmission systems

## Product Descriptions

Inscap Data's LinkPower™ LPS LC SM 2632/2632i Single Mode SFP transceivers are high performance and cost effective modules supporting dual data-rate of 1.25Gbps/1.0625Gbps and 20km transmission distance with SMF. The transceiver consists of three sections: a FP laser transmitter, a PIN photodiode integrated with a trans-impedance preamplifier (TIA) and MCU control unit. All modules satisfy class I laser safety requirements. The transceivers are compatible with SFP Multi-Source Agreement (MSA) and SFF-8472. For further information, please refer to SFP MSA.

## Functional Diagram

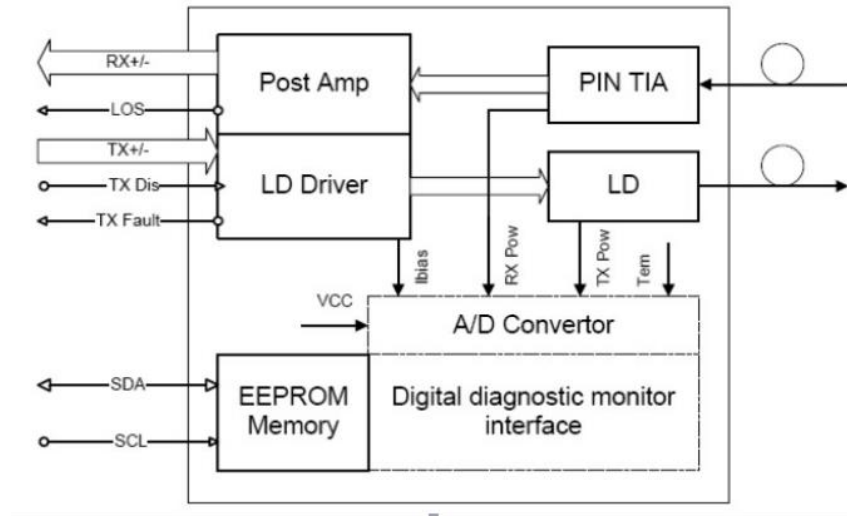

## Absolute Maximum Ratings

Parameter	Symbol	Min.	Max.	Unit	Note
Supply Voltage	Vcc	-0.5	4.0	V	
Storage Temperature	Ts	-40	85	°C	
Relative Humidity	RH	0	85	%	

**Note:** Stress in excess of the maximum absolute ratings can cause permanent damage to the transceiver.

## General Operating Characteristics

Parameter	Symbol	Min.	Type	Max.	Unit	Note
Data Rate	DR	1.0625	1.25		Gb/s	
Supply Voltage	Vcc	3.13	3.3	3.47	V	
Supply Current	Iccs			220	mA	
Operating Case Temp.	Tc	0		70	°C	
	Tl	-40		85		

Inscap Data Corporation  
 1620 Oakland Road, Suite D101, San Jose, CA 95131, U.S.A.  
**PHONE:** +1.408.392.9800 **FAX:** +1.408.392.9812  
**Corporate Website:** www.inscapedata.com  
**EMAIL:** sales@inscapedata.com

© Copyright 2018, Inscap Data Corporation, All Rights Reserved. LinkPower and Inscap Data are trademarks of Inscap Data Corporation, REV. 1.1  
 Disclaimer: While every effort is made to ensure the information given is accurate, Inscap Data Corporation does not accept liability for any errors or mistakes which may arise. All specifications are subject to change without notice.

## Electrical Characteristics (T<sub>OP(C)</sub> = 0 to 70 °C, V<sub>CC</sub> = 3.13 to 3.47 V)

Parameter	Symbol	Min.	Type	Max.	Unit	Note
<b>Transmitter</b>						
Differential data input swing	V <sub>IN,PP</sub>	120		820	mVpp	1
Tx Disable Input-High	V <sub>IH</sub>	2.0		V <sub>CC</sub> +0.3	V	
Tx Disable Input-Low	V <sub>IL</sub>	0		0.8	V	
Tx Fault Output-High	V <sub>OH</sub>	2.0		V <sub>CC</sub> +0.3	V	2
Tx Fault Output-Low	V <sub>OL</sub>	0		0.5	V	2
Input differential impedance	R <sub>in</sub>		100		Ω	
<b>Receiver</b>						
Differential data output swing	V <sub>out,pp</sub>	300	650	800	mVpp	3
Rx LOS Output-High	V <sub>ROH</sub>	2.0		V <sub>CC</sub> +0.3	V	2
Rx LOS Output-Low	V <sub>ROL</sub>	0		0.8	V	2

### Notes:

1. TD+/- are internally AC coupled with 100Ω differential termination inside the module.
2. Tx Fault and Rx LOS are open collector outputs, which should be pulled up with 4.7k to 10kΩ resistors on the host board. Pull up voltage between 2.0V and V<sub>CC</sub>+0.3V.
3. RD+/- outputs are internally AC coupled, and should be terminated with 100Ω (differential) at the user SERDES.

## Optical Characteristics (T<sub>OP(C)</sub> = 0 to 70 °C, V<sub>CC</sub> = 3.13 to 3.47 V)

Parameter	Symbol	Min.	Type	Max.	Unit	Note
<b>Transmitter</b>						
Operating Wavelength	λ	1270	1310	1360	nm	
Ave. output power (Enabled)	P <sub>AVE</sub>	-9		-3	dBm	1
Extinction Ratio	ER	9			dB	1
RMS spectral width	Δλ			0.65	nm	
Rise/Fall time (20%~80%)	Tr/Tf			0.26	ns	2
Dispersion penalty	T <sub>DP</sub>			3.9	dB	
Output Optical Eye	Compliant with IEEE802.3 z (class 1 aser safety)					
<b>Receiver</b>						
Operating Wavelength	λ	1260		1610	nm	
Receiver Sensitivity	P <sub>SEN1</sub>			-22	dBm	3
Overload	P <sub>AVE</sub>	-3			dBm	3
LOS Assert	P <sub>a</sub>	-35			dBm	
LOS De-assert	P <sub>d</sub>			-24	dBm	
LOS Hysteresis	P <sub>d</sub> -P <sub>a</sub>	0.5			dB	

### Notes:

Inscap Data Corporation  
 1620 Oakland Road, Suite D101, San Jose, CA 95131, U.S.A.  
**PHONE:** +1.408.392.9800 **FAX:** +1.408.392.9812  
**Corporate Website:** www.inscapedata.com  
**EMAIL:** sales@inscapedata.com

1. Measured at 1250Mb/s with PRBS  $2^{23}-1$  NRZ test pattern.
2. Unfiltered, measured with a PRBS  $2^{23}-1$  test pattern @1.25Gbps
3. Measured at 1250Mb/s with PRBS  $2^{23}-1$  NRZ test pattern for BER <  $1 \times 10^{-12}$

## Pin Definition And Functions

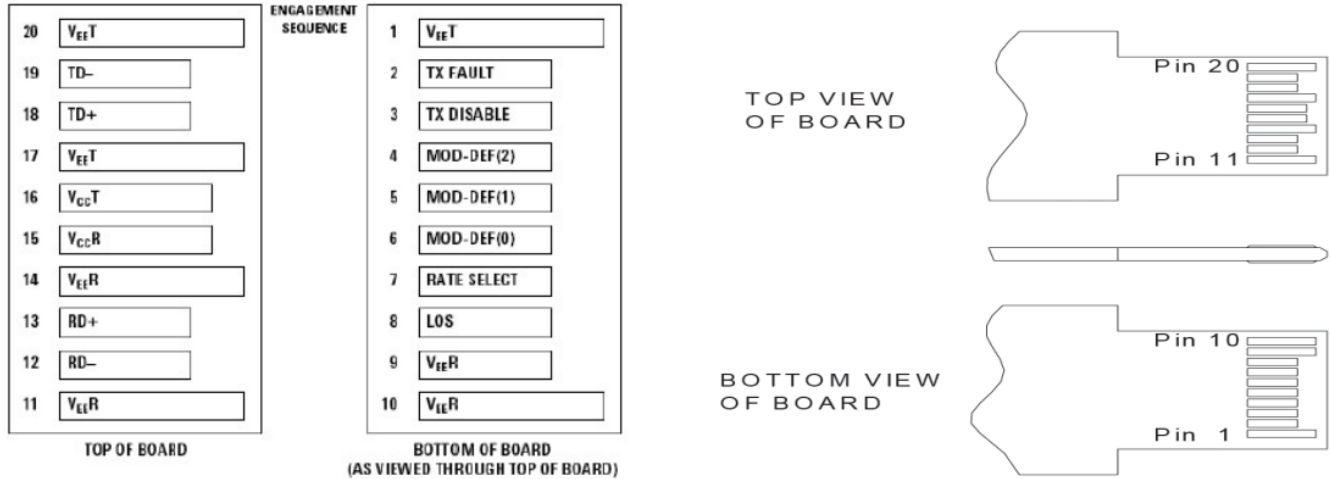

Pin	Symbol	Name/Description	Notes
1	V <sub>EE</sub> T	Tx ground	
2	Tx Fault	Tx fault indication, Open Collector Output, active “H”	1
3	Tx Disable	LVTTL Input, internal pull-up, Tx disabled on “H”	2
4	MOD-DEF2	2 wire serial interface data input/output (SDA)	3
5	MOD-DEF1	2 wire serial interface clock input (SCL)	3
6	MOD-DEF0	Model present indication	3
7	Rate select	No connection	
8	LOS	Rx loss of signal, Open Collector Output, active “H”	4
9	V <sub>EE</sub> R	Rx ground	
10	V <sub>EE</sub> R	Rx ground	
11	V <sub>EE</sub> R	Rx ground	
12	RD-	Inverse received data out	5
13	RD+	Received data out	5
14	V <sub>EE</sub> R	Rx ground	
15	V <sub>CC</sub> R	Rx power supply	
16	V <sub>CC</sub> T	Tx power supply	
17	V <sub>EE</sub> T	Tx ground	

Inscap Data Corporation  
 1620 Oakland Road, Suite D101, San Jose, CA 95131, U.S.A.  
**PHONE:** +1.408.392.9800 **FAX:** +1.408.392.9812  
**Corporate Website:** www.inscapedata.com  
**EMAIL:** sales@inscapedata.com

18	TD+	Transmit data in	6
19	TD-	Inverse transmit data in	6
20	VeeT	Tx ground	

**Notes:**

- When high, this output indicates a laser fault of some kind. Low indicates normal operation. And should be pulled up with a 4.7 – 10KΩ resistor on the host board.
- TX disable is an input that is used to shut down the transmitter optical output. It is pulled up within the module with a 4.7 – 10KΩ resistor. Its states are:  
Low (0 – 0.8V): Transmitter on                      (>0.8, < 2.0V): Undefined  
High (2.0V~Vcc+0.3V): Transmitter Disabled    Open: Transmitter Disabled
- Mod-Def 0,1,2. These are the module definition pins. They should be pulled up with a 4.7K – 10KΩ resistor on the host board. The pull-up voltage shall be between 2.0V~Vcc+0.3V.  
Mod-Def 0 has been grounded by the module to indicate that the module is present  
Mod-Def 1 is the clock line of two wire serial interface for serial ID  
Mod-Def 2 is the data line of two wire serial interface for serial ID
- When high, this output indicates loss of signal (LOS). Low indicates normal operation.
- RD+/-: These are the differential receiver outputs. They are AC coupled 100Ω differential lines which should be terminated with 100Ω (differential) at the user SERDES. The AC coupling is done inside the module and is thus not required on the host board.
- TD+/-: These are the differential transmitter inputs. They are AC-coupled, differential lines with 100Ω differential termination inside the module. The AC coupling is done inside the module and is thus not required on the host board.

## Digital Diagnostic Specifications

The 2632 transceivers can be used in host systems that require either internally or externally calibrated digital diagnostics.

Parameter	Symbol	Units	Min.	Max.	Accuracy	Note
Transceiver temperature	DTemp-E	°C	-5	+75	±5°C	
Transceiver supply voltage	DVoltage	V	2.8	4.0	±3%	
Transmitter bias current	DBias	mA	2	15	±10%	1
Transmitter output power	DTx-Power	dBm	-12	-1	±3dB	
Receiver average input power	DRx-Power	dBm	-25	0	±3dB	

**Notes:**

- The accuracy of the Tx bias current is 10% of the actual current from the laser driver to the laser
- Internal/ External Calibration compatible.

## Typical Interface Circuit

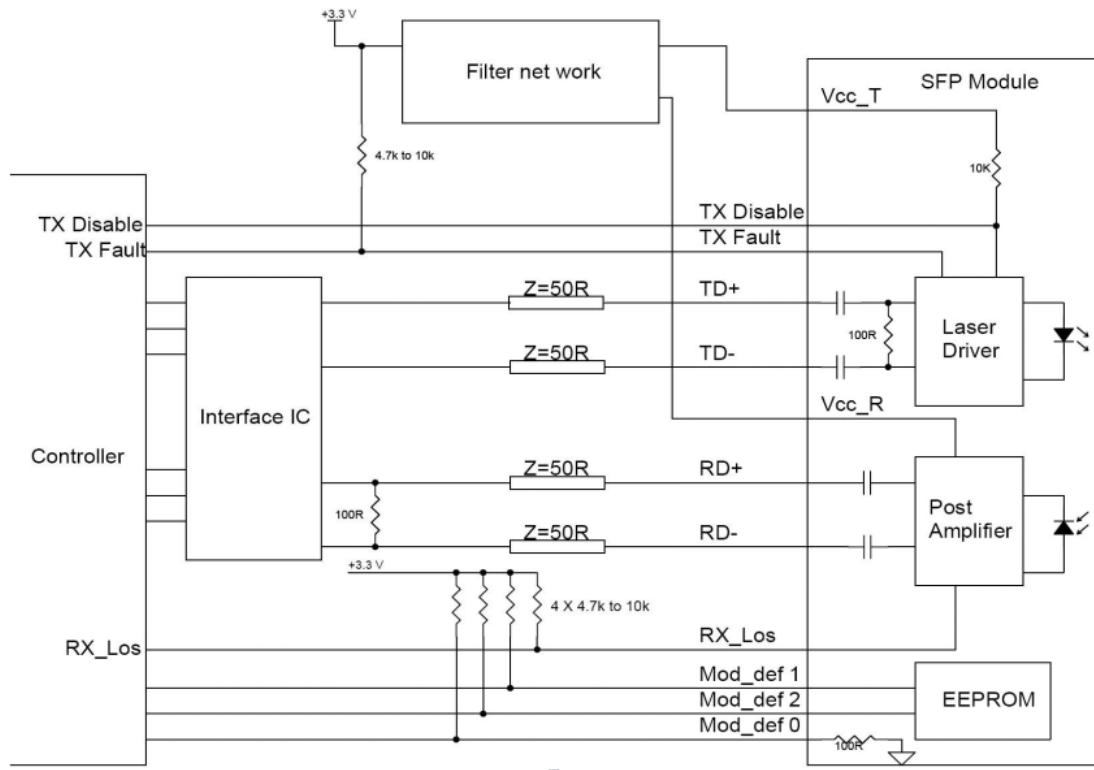

## Package Dimensions

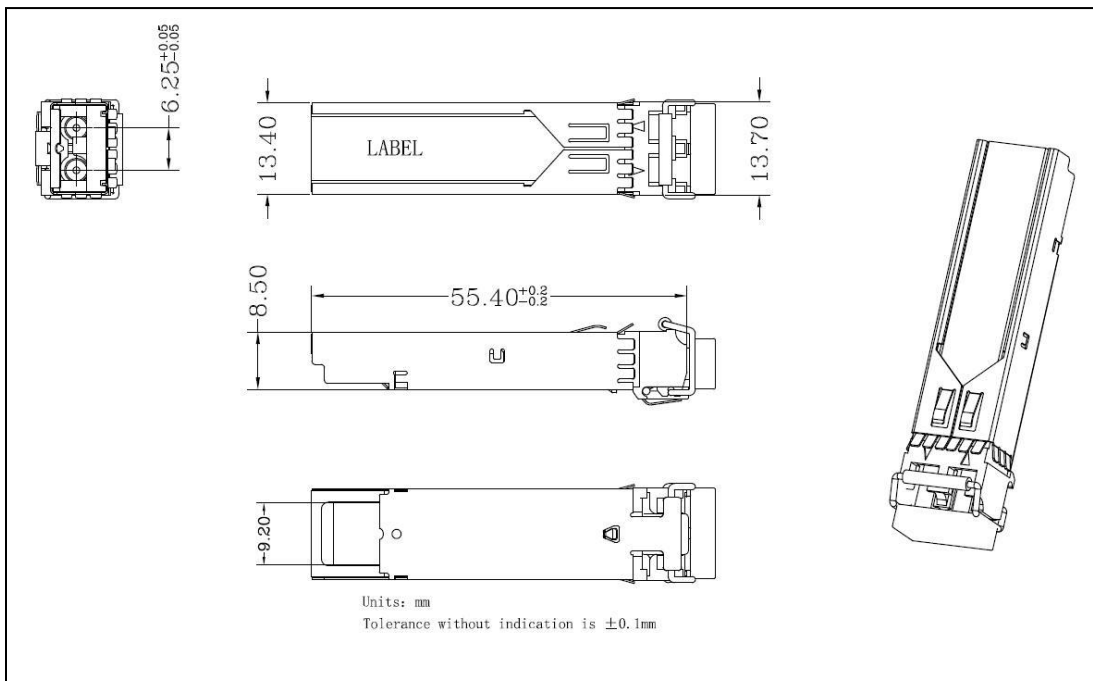

Inscape Data Corporation  
 1620 Oakland Road, Suite D101, San Jose, CA 95131, U.S.A.  
**PHONE:** +1.408.392.9800 **FAX:** +1.408.392.9812  
**Corporate Website:** www.inscapedata.com  
**EMAIL:** sales@inscapedata.com

© Copyright 2018, Inscape Data Corporation, All Rights Reserved. LinkPower and Inscape Data are trademarks of Inscape Data Corporation, REV. 1.1  
 Disclaimer: While every effort is made to ensure the information given is accurate, Inscape Data Corporation does not accept liability for any errors or mistakes which may arise.  
 All specifications are subject to change without notice.

## Ordering Information

Part Number	Description
LPS SM 2632 LC	SFP, 1.25G, Dual Fiber, 1310nm, 20Km, 0 ~ 70°C, with DDM, Commercial Grade
LPS SM 2632i LC	SFP, 1.25G, Dual Fiber, 1310nm, 20Km, -40 ~ 85°C, with DDM, Industrial Grade

Inscape Data Corporation  
1620 Oakland Road, Suite D101, San Jose, CA 95131, U.S.A.  
**PHONE:** +1.408.392.9800 **FAX:** +1.408.392.9812  
**Corporate Website:** [www.inscapedata.com](http://www.inscapedata.com)  
**EMAIL:** [sales@inscapedata.com](mailto:sales@inscapedata.com)

© Copyright 2018, Inscape Data Corporation, All Rights Reserved. LinkPower and Inscape Data are trademarks of Inscape Data Corporation, REV. 1.1  
Disclaimer: While every effort is made to ensure the information given is accurate, Inscape Data Corporation does not accept liability for any errors or mistakes which may arise.  
All specifications are subject to change without notice.